

GROUP 482 MORSE TAPER SLEEVES

KENNEDY Morse Taper Tooling

A range of quality traditional workholding equipment. Manufactured from high quality steel and case hardened all over. All sleeves and sockets are fully hardened and ground internally and externally.

ISO 238 BS 1660 : 2.

Morse Taper Sleeve Data

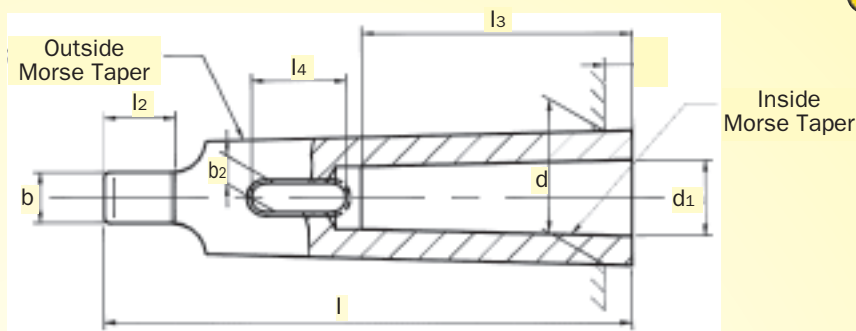

| MT | | l | d | b | l2 | d1 | l3 | l4 | b2 |
|--------|---------|--------|--------|--------|--------|--------|---------|--------|--------|
| Inside | Outside | | | | | | | | |
| 1 | 2 | 92.00 | 17.780 | 6.350 | 11.112 | 12.065 | 52.388 | 19.050 | 5.410 |
| 1 | 3 | 99.00 | 23.825 | 7.938 | 14.288 | 12.065 | 52.388 | 19.050 | 5.410 |
| 2 | 3 | 112.00 | 23.825 | 7.938 | 14.288 | 17.780 | 63.500 | 22.225 | 6.604 |
| 1 | 4 | 124.00 | 31.267 | 11.906 | 15.875 | 12.065 | 52.388 | 19.050 | 5.410 |
| 2 | 4 | 124.00 | 31.267 | 11.906 | 15.875 | 17.780 | 63.500 | 22.225 | 6.604 |
| 3 | 4 | 140.00 | 31.267 | 11.906 | 15.875 | 23.825 | 77.788 | 30.162 | 8.179 |
| 1 | 5 | 156.00 | 44.399 | 15.875 | 19.050 | 12.065 | 52.388 | 19.050 | 5.410 |
| 2 | 5 | 156.00 | 44.399 | 15.875 | 19.050 | 17.780 | 63.500 | 22.225 | 6.604 |
| 3 | 5 | 156.00 | 44.399 | 15.875 | 19.050 | 23.825 | 77.788 | 30.162 | 8.179 |
| 4 | 5 | 171.00 | 44.399 | 15.875 | 19.050 | 31.267 | 98.425 | 31.750 | 12.141 |
| 1 | 6 | 218.00 | 63.348 | 19.050 | 28.575 | 12.065 | 52.388 | 19.050 | 5.410 |
| 2 | 6 | 218.00 | 63.348 | 19.050 | 28.575 | 17.780 | 63.500 | 22.225 | 6.604 |
| 3 | 6 | 218.00 | 63.348 | 19.050 | 28.575 | 23.825 | 77.788 | 30.162 | 8.179 |
| 4 | 6 | 218.00 | 63.348 | 19.050 | 28.575 | 31.267 | 98.425 | 31.750 | 12.141 |
| 5 | 6 | 218.00 | 63.348 | 19.050 | 28.575 | 44.399 | 125.412 | 38.100 | 16.129 |

Drill Sleeves

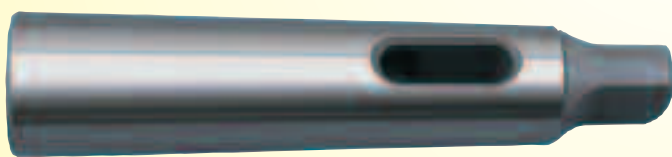

| Taper Inside x Outside | Length (mm) | Weight each | Order Code KEN-482 |
|------------------------|-------------|-------------|--------------------|
| 1 x 2 MT | 95 | 110g | -2120K |
| 1 x 3 MT | 97 | 220g | -2130K |
| 1 x 4 MT | 120 | 560g | -2140K |
| 1 x 5 MT | 152 | 1500g | -2150K |
| 2 x 3 MT | 110 | 200g | -2230K |
| 2 x 4 MT | 123 | 490g | -2240K |
| 2 x 5 MT | 155 | 1500g | -2250K |
| 3 x 4 MT | 140 | 430g | -2340K |
| 3 x 5 MT | 155 | 1200g | -2350K |
| 4 x 5 MT | 170 | 1100g | -2450K |
| 4 x 6 MT | 215 | 3600g | -2460K |
| 5 x 6 MT | 225 | 2800g | -2560K |

Drill Drifts

To release Morse Taper Tooling without damaging machine socket or tools.

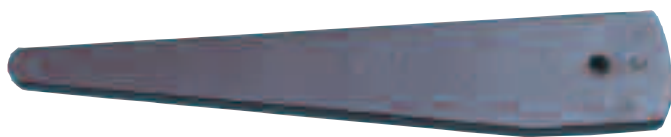

| To Release Morse Taper | Weight each | Order Code KEN-482 |
|------------------------|-------------|--------------------|
| 0 | 40g | -9500K |
| 1 & 2 | 80g | -9520K |
| 3 | 220g | -9530K |
| 3 & 5 | 380g | -9540K |
| 5 & 6 | 760g | -9560K |

Extension Sockets



| Taper Inside x Outside | Length (mm) | Weight each | Order Code KEN-482 |
|------------------------|-------------|-------------|--------------------|
| 1 x 1 MT | 145 | 275g | -4110K |
| 1 x 2 MT | 160 | 290g | -4120K |
| 2 x 1 MT | 175 | 300g | -4210K |
| 2 x 2 MT | 175 | 390g | -4220K |
| 2 x 3 MT | 194 | 710g | -4230K |
| 3 x 2 MT | 194 | 620g | -4320K |
| 3 x 3 MT | 230 | 750g | -4330K |
| 3 x 4 MT | 255 | 1400g | -4340K |
| 4 x 3 MT | 255 | 1500g | -4430K |
| 4 x 5 MT | 300 | 3000g | -4450K |
| 5 x 4 MT | 300 | 2500g | -4540K |

Drill Sleeve & Drift Set

Set of three drill sleeves 1 - 2, 2 - 3, 3 - 4 MT. Fully hardened and ground inside and out. Two drill drifts to release 1 - 2 and 3 - 4 MT.

5 PIECES



| No. of Pieces | Weight Set | Order Code KEN-482 |
|---------------|------------|--------------------|
| 5 | 995g | -9900K |

WORKSHOP EQUIPMENT

