

INDEXA Horizontal & Vertical Index Unit Chucks

Ideal for indexing items to be machined in pre-set or manually set incremental angles. Indexing accuracy 25 seconds. Angular indexing through the graduation ring from 0 to 360 degrees in 1 degree increments. Basic indexing by means of a catch device permitting divisions of 2, 3, 4, 6, 8, 12 and 24 without disassembly. Fitted with standard three jaw self-centring scroll chuck with two sets of jaws, for inside and outside gripping.

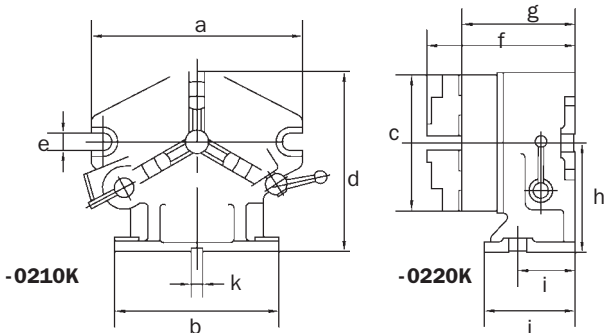

WORKSHOP EQUIPMENT



Chuck Diameter	Dimensions (mm)											Weight each	Order Code
	A	B	C	D	E	F	G	H	I	J	K		
167mm	260	220	167	220.00	18	197.5	155.5	130.00	70	130	16	17.8kg	-0210K
220mm	310	255	210	255.25	18	214.0	171.5	149.25	80	150	16	94.0kg	-0220K

Type SOPP Horizontal & Vertical Rotary Tables

With a disengageable worm gear which allows rapid indexing. One rotation of handle equals four degrees on collar. The table is made of high grade cast iron. Works as an indexing unit in the vertical position as well as a conventional rotary table for circular cutting, boring or angle setting, etc. Optional dividing plates are available separately.

Accuracy:

- Parallelism of clamping surface to base: 0.020mm
- Flatness of clamping surface: 0.015mm
- True running cylindrical centre bore: 0.020mm
- True running of tapered centre bore: 0.020mm
- Squareness of clamping surface to centre slot: 0.010mm

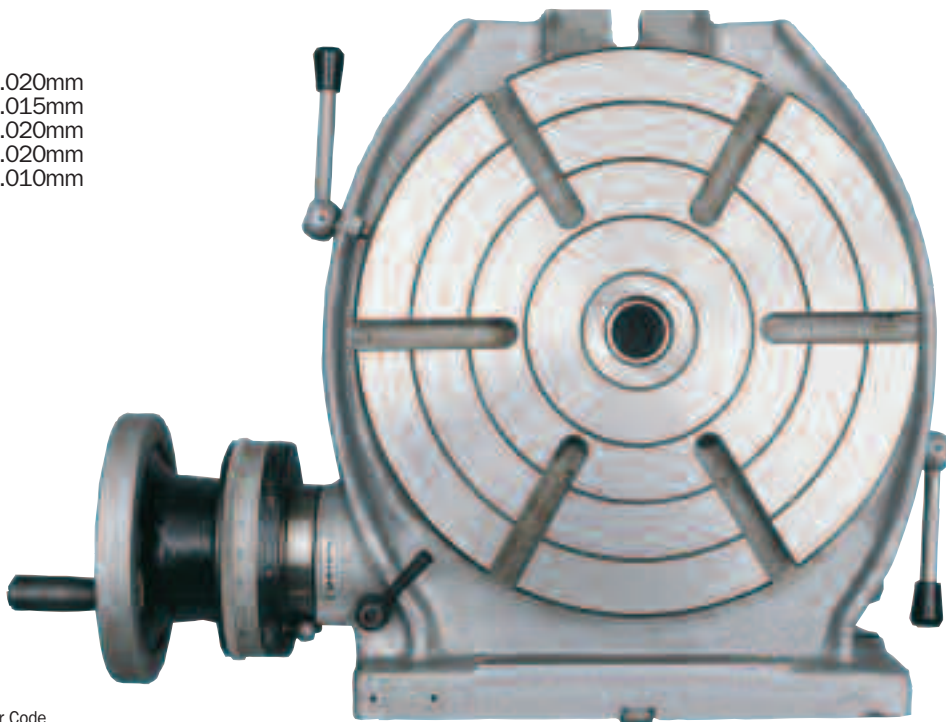
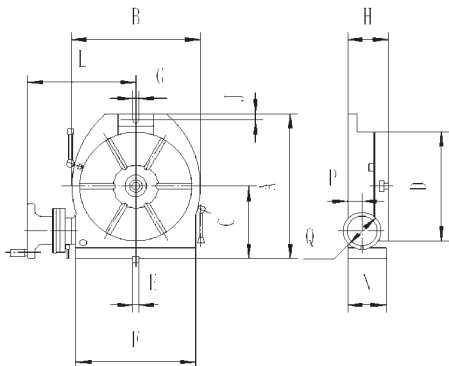

Optional Extras

Description	Order Code
Dividing Plate for INDEXA Rotary Tables	-1000K

Rotary Tables

Diameter D	Max. Capacity C	Centre Hole M	Dimensions (mm)											No. of T-slots	Weight each	Order Code
			A	B	E	F	G	H	J	L	N	P	Q			
200mm	150	3 MT	285	236	14	208	14	100	15	211	99	48	125	4	42kg	-0500K
250mm	170	3 MT	328	286	14	253	14	110	16	241	106	48	125	6	57kg	-0510K
320mm	210	4 MT	410	360	18	320	18	120	16	273	118	48	140	6	92kg	-0520K

PRODUCTS ARE ONLY AVAILABLE VIA YOUR DISTRIBUTOR